

Hi-tech **EZ-ROLL™** Keyway-Lifters

(Because needles are old news!)

*Patent Pending

.937 & 1.062 dia Keyway style REDZONE™ Roller Lifters equipped standard with our exclusive NEEDLE-FREE EZ-ROLL™ Bearings!

The proliferation of modern valve-trains (i.e. aggressive cam profiles, higher rocker arm ratios and 1,200 lb. PLUS open pressure valve springs) have often seen even the oversized/overpriced specialty roller lifters quickly succumb to

premature needle bearing over-load failure! The phenomenal success of our “needle free” **EZ-ROLL™** Bearing option for conventional Isky **RED-ZONE™** “tie-bar” style Roller Lifters has spawned their extension to the next platform:

By popular demand of major engine builders and racers across the country, we proudly announce this revolutionary patent-pending design technology is now available for Keyway Style Roller Lifters! After months of development at the Isky Spintron® research facility and in the field, the fail-safe peace of mind alternative to needle-roller bearings will soon change the way professional racers view their roller lifter needs forever! **EZ-ROLL™** Keyway Roller Lifters are suitable for hi-end circle track, offshore marine and drag race applications employing modified lifter bore spaced blocks (where it's difficult or impossible to install tie-bar style rollers). See page 28 for the **EZX™** & **EZMAX™** **EZ-ROLL™** lifter bearing descriptions.

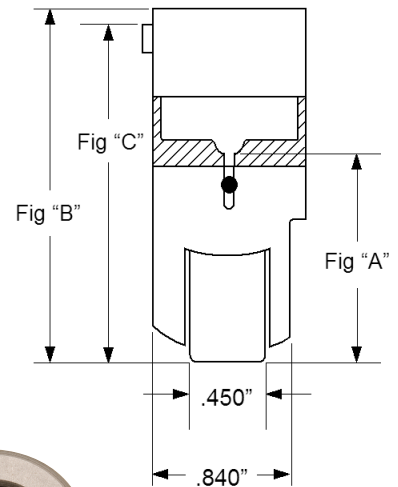

SL-1062



936K

precision ground polished body



ISKY's Revolutionary New Wide Foot Print Low Friction EZ-Roll Bearing!

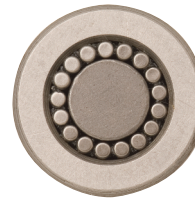

“Traditional Needle-Roller Bearing and it's small load distribution footprint.”

EZ-ROLL™ Keyway Lifter Part No.	Body Diameter	Bearing Diameter	Pushrod Seat Location	Body Style	Weight (Grams)	Pushrod Seat Height (Fig A)	Overall Length (Fig B)	Key Height (Fig C)
•936KEZX	.936"	.850"	(16) Centered	Open Body	119 g	1.290"	2.130"	2.030
•936K050EZX	.936"	.850"	(16) .050" Offset	Open Body	119 g	1.290"	2.130"	2.030
•936K150EZX	.936"	.850"	(16) .150" Offset	Open Body	119 g	1.290"	2.130"	2.030
•937KEZX	.936"	.850"	(16) Centered	Open Body	123 g	1.290"	2.280"	*2.180
•937K050EZX	.936"	.850"	(16) .050" Offset	Open Body	123 g	1.290"	2.280"	*2.180
•937K150EZX	.936"	.850"	(16) .150" Offset	Open Body	123 g	1.290"	2.280"	*2.180
-SL1062KEZMAX	1.061"	.920"	(16) Centered	Shrouded Body	144 g	1.440"	2.150"	2.060

*Key Height is raised .150"

•**EZX™** bearing standard: add \$50.00 premium for **EZ-MAX™**

-**EZMAX™** bearing standard:

ROLL “EZ”



.... **RED-ZONE™ Safe!**